

PAPRIKA! HANDS ON.

Graphic Design:
Martin Bek

Coordinating Editor:
Nicolas Kemper and Andrew Sternad

Issue Editors:
Dortan Booth and Jessica Angel

September 18
2015
(FOLD VII)

ON THE GROUND

The Dean Selection Committee has finished its work, having submitted a list of names - some more endorsed than others - to President Salovey, possibly as far back as June. There is a rumor currently at SHOP that GREGG PASQUARELLI might be one of them. An older rumor named KELLER EASTERLING - the head of the Dean Selection Committee. Word is also that members of the office of DEBORAH BERKE have been making visits to New Haven, and that the principal herself has been making an effort to meet the denizens of floor three.

9/10

"The worst thing that can happen to a designer is to have their first design built," said Dean ROBERT A.M. STERN (M.Arch '65) in the question-and-answer session for the CAPLES JEFFERSON lecture.

"There's a reason those houses look like little Dutch houses," said SARAH CAPLES (M.Arch '74) in a powerful and simple explanation of larger forces at play in the Weeksville Heritage Center, in Brooklyn, designed by Caples and fellow Louis I. Kahn Visiting Assistant Professor EVERARDO JEFFERSON (M.Arch '73). Presented with their remarkable design for Brooklyn's largest African-American cultural institution on the historic site of one of America's first free black communities, another audience might have joined in a discussion about "passing" and the potential for ornament to run deeper than surface. Instead, four predictable questions about form basically missed the point.

9/11

"One of the best things about Babel - ironically is that you can understand it in many different languages," said KYLE DUGDALE (PhD '15) in the first meeting of his seminar, Babel. No stranger to teaching here as a PhD student and long time teacher of the history component of Summer Visualization, Kyle joins us this year as a member of the faculty.

6on7? It's a party!

9/14

In his seminar Parallels of the Modern, Dean ROBERT A.M. STERN led a romp through northern climes. Want to crack Aldo Rossi's code? Take a look at LeWentz. Dean Stern warned against considering Alvar Aalto a "happy woodsman" and against reading too much into the meaning of certain words, including "Fuhrer" and "Master." At the Rome drawing reception, the Dean

announced that last year marked the end of ALEC PURVES (B.A. '58, M.Arch '65) as head of the Rome summer program. Begun with STEPHEN HARBY (M.Arch '80), next year the program will be led by JOYCE HSIANG and BIMAL MENDIS.

9/15

Why earn a license? To become an "architect," read the slide in the Tuesday evening licensure talk by NCARB advisor MICHAEL AXLES (AIA, NCARB). Among the exciting developments in our ever evolving licensing process is that we only need 3740 hours - instead of 5600 - to earn our license, and that the exams now cost \$60 less.

"Search Versus Re-Search: Josef Albers, Artist and Educator" opened at the Yale School of Art with a pizza and beer reception.

9/16

"This is the math Donald Trump can do," began KEVIN GRAY's introduction to the capitalization rate in his Commercial Real Estate class. The harder stuff - what Trump can't do - comes later this semester.

9/17

"What's Yale's problem with green?" exclaimed MARION WEISS (M.Arch '84) upon reviewing her advanced studio's campus precedent diagrams, which lacked color for trees and lawns. She took a green pencil to the drawings to remedy the apparent fear of landscape.

MARTIN FINIO urged his second year studio to take a position on both site and pedagogy, intoning his students to "think about what it means to be human in the world!"

"Originality is king in the kingdom of fools," quipped PETER EISENMAN in first year Formal Analysis. For the first time, the class presented drawings digitally, focusing this week on San Lorenzo and Santo Spirito. The move to the big screen was prompted in part by a "smudge epidemic": Hull's supplied the wrong mylar, which caused ink to run.

PETER EISENMAN bragged to his advanced studio, "I've been camping more than all of you combined; try two years without a shower," eliciting jokes about his "primitive hut" period.

KURT FORSTER appeared on ELIA ZENGHELIS' advanced studio review of "image manifests." Forster alluded to LED ZEPPELIN's "Stairwell to Heaven" [sic], while Zenghelis quoted KEVIN COSTNER's character in Field of Dreams: "If you build it, they will come."

Preparing urban study models for the PORPHYRIOS studio, BORIS MORIN-DEFOY (M.Arch '16) wrote a grasshopper script for mass producing pitched roofs.

Captain SUNIL BALD and Lieutenant NICHOLAS McDERMOTT guided their starship of self-styled "darkitects" where no advanced studio has gone before: toward spheres, the shape of darkness, and a visit to the dark side of more than a few students' psyches. These junior cosmonauts still have a long way to go; one lunar diagram labeled the "pedigree" of the moon. That would be "pedigree," Mr. Spock. Fascinating.

"An example of where the restoration of something is its most effective suppression," said KURT FORSTER of the new Schloss being erected in Berlin in the question session for the lecture of KATHLEEN JAMES-CHAKRABORTY, "The Architecture of Modern Memory: Building Identity in Democratic Germany."

ALAN PLATTUS' (B.A. '76) advanced studio leaves for Beijing on the 22nd, a week before the rest of the advanced studios. A collaboration with Tsinghua University architecture students and a lecture by Dean Stern at the Yale Beijing Center will be highlights of the trip to China's sprawling capital city.

9/18

6on7 tonight, where'syourhead@, competes with the Architecture League of New York's Beaux Arts Ball, THRESHOLD. A ticket to the ball? \$100. We know where we'll be.

The views expressed in Paprika! do not represent those of the Yale School of Architecture. Please send all comments and corrections to paprika.ysoa@gmail.com.

As PAPRIKA! is published on the occasion of public lectures, there will be no issue published next week.

EDITORIAL

"I learned this, at least, by my experiment: that if one advances confidently in the direction of his dreams, and endeavors to live the life which he has imagined, he will meet with a success unexpected in common hours."

— Henry David Thoreau, *Walden*:
Or, Life in the Woods

In this fold we would like to explore the notion of independent work in all of its manifestations: what it means to be "hands on" with the actual production of architectural, artistic, theoretical, or design work outside of the purview of school or professional environments. What are the alternative paths that one can take? In a time when work is largely produced under the authority of institutions or firms, can agency be reclaimed through independent projects? This fold is an attempt to show that there are possibilities of producing meaningful work at a scale that is accessible to independent pursuits.

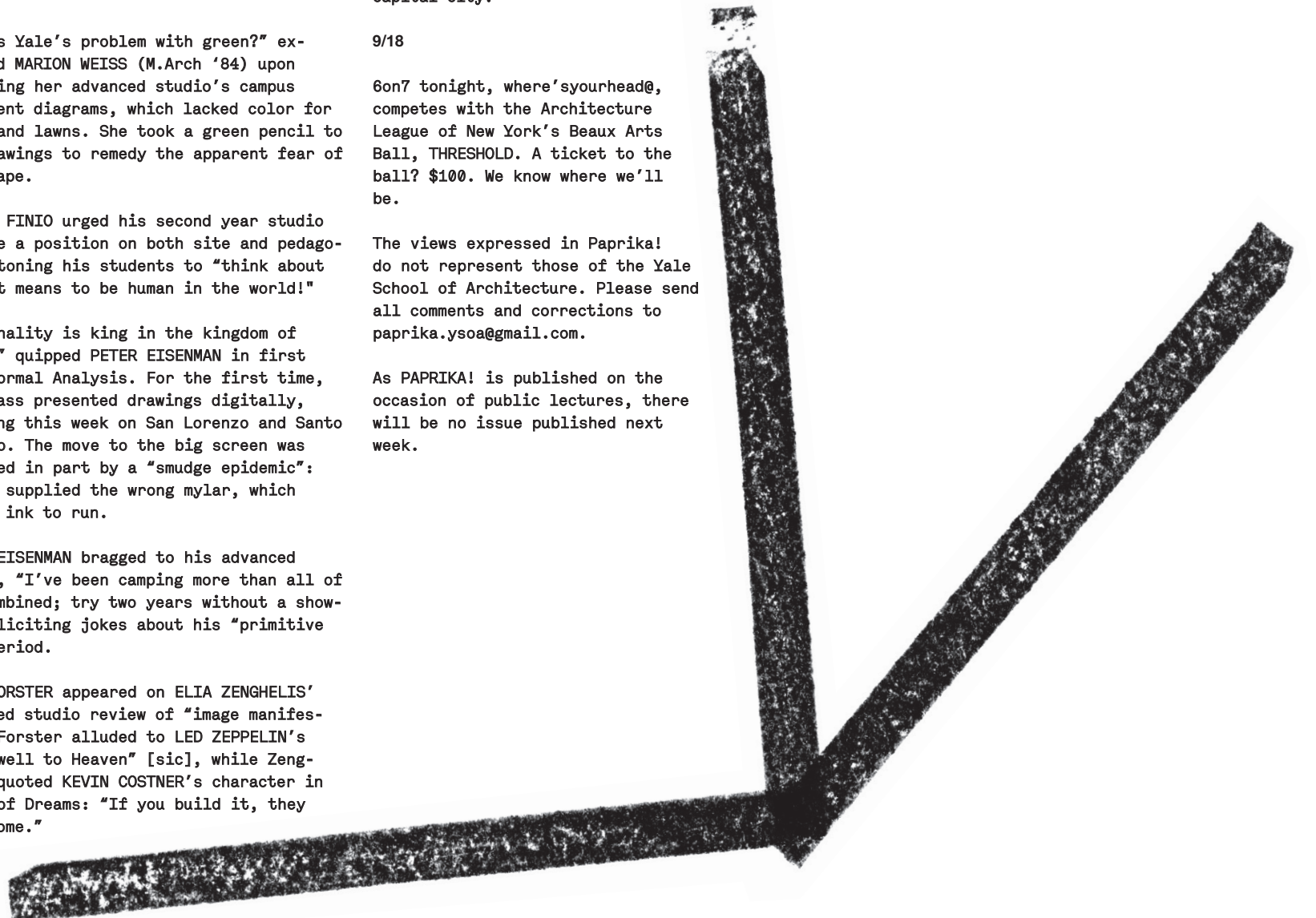

TEARDROP



I left the architecture department because I was exhausted by it and by myself. I was tired of "smart moves", delivered without style or humor, which felt neither smart nor moving. Tired of the emperor's-new-clothes-type pressure to "understand" things that are clearly not to be understood. Enough cheap Ayn Rand behavior, equating rudeness and self-flagellation with passion and control! I was racing along at such a self-defeating pace that I lost the joy, surprise, and people in my life that together represent my only chance of making work that feels like anything. And I'm not alone in abhorring the bodily consequences, the toxic ache that comes from running on coffee and adrenaline. At the end of it, I saw only a foreseeable future defending projects that I think shouldn't happen in the first place. I missed ugliness, accidents, and generosity. I was lonely.

Instead, I would prefer to not understand. Good things happen when I can sleep nine hours a night and have time to do a double take at nearly everything. It's a productive release to consider outcomes as incidental byproducts of a process and it's a pleasurable release to build only when it feels necessary. I think it was scarred into me that I need to pay attention to exhaustion when it comes and to opt out freely. I learned that wallowing in contingency, forgetfulness, and loose control is the only way I want to work. Above all, I hope to go slower.

Leaving the program gave me a heady rush of energy and autonomy. And the space to use these new commodities. One indirect consequence of quitting was a project this past summer where I built a teardrop trailer as I towed it through the west. It was practice with Slow Design and, if nothing else, a pleasure.

Last Friday I went to check on my trailer where it's tucked into the woods and under a

tarp in East Haven. I had been worried that water was somehow invading, now that I'm no longer living in it. But when I unclamped and opened the door everything was how I left it when I wrapped it up a few weeks ago: clean, dry, white, brown, and sweet-smelling. It's only been two weeks but I'm glad I went for the heavy-duty tarp!

This was something that kept coming up during the summer, as I drove past and rummaged through so many abandoned buildings: all materials are water-soluble at the right time scale. Or the corollary: the only real way to waterproof a structure is to have someone live in it. It's breath-taking how quickly buildings melt if they're left alone. Habitation is everything.

My project, nominally, was to build a teardrop trailer as I towed it along a big western loop. It has a 5'x10' chassis that used to be a heavy ATV trailer, and the walls have a teardrop profile. There's a living space with a pop-up roof in front, a bulkhead wall, and then an outdoor kitchen galley under a pop-up awning in back. The 3-month, 7,000-mile loop started and ended in the Hudson Valley, but most of my time was spent between New Mexico and Montana, visiting ranches managed by friends and trading help for use of their shops.

What became clear over this period was that living in and building the trailer was essentially contingent. In building, the exigencies and limitations of roadside construction constantly humbled and tempered my plans. In operation, I had to ask for help for everything. If I wanted a shower, to fill my water tank, to scavenge for

materials, to park somewhere for the night, I needed people. The trailer now seems literally built out of some social fabric as much as it is out of wood, foam, steel, etc.

For this reason, I felt hesitant when I was grouped with the zealous tiny house crowd, even though I think many of those buildings are very beautiful. "Off the grid" living has a strident flavor, proud of a purported independence that doesn't really exist (and would be unfortunate and lonely if it did). Who made the solar panels? The fasteners and panes of glass? The composting toilet? These little buildings are only ever (sort of) independent and insulated at a very short time scale and by very selective accounting. In reality, even these mini structures are, in their construction, use, and eventual demise, the hardened confluence of much larger energy systems. They are no different than any other construction.

In fact, the thrill of living and working with the trailer this summer was the way it forced honesty about my dependency and contingency. At this smallest scale, with such literally and figuratively thin walls, this was a palpable daily reality. Things broke all the time. If it and I couldn't respond to changing patterns of use and the changing environment, we would have never made it back home.

In the trailer, I could deal with this. In fact, dependence became my biggest design resource. Everything was revision and the process was endless. Nothing was so large that I couldn't get into it. As a result, I felt delightfully out-of-control throughout the process of making the trailer and

finally comforted by the space as it came to exist. I was constantly surprised by the way things looked and rarely, if ever, had to force the issue.

But, I don't know how this scales up. Large structures and modern construction marshal phenomenal resources to hide their dependency, but they aren't exempt. However, because they're saturated with energy and ambition, they seem fated to fixity. And because of this—if the buildings are unable to flex, if the users are disempowered from making the revisions that keep the space viable and pleasurable—it seems inevitable that the people will leave. After the people leave, I doubt the building has a year to live, which is a kind of tragic way to squander human and material energy.

In a New Yorker cartoon, two construction workers are looking at the foundations of a big building-to-be and one says to the other, "I don't know... seems like a lot of work." For me, this is entirely it. What am I arguing for? For letting ourselves get tired. For having an itchy quitting trigger finger. The way we work is finally far more important than what we work on. If it doesn't feel right, it's probably not worth doing.



AS MANY AS WE WANT

J: Hi Levi, can you tell us a little bit about you and Pneuhaus?

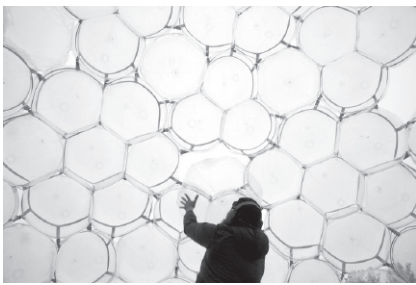

L: Pneuhaus is a young design practice which focuses on pneumatic construction techniques and spatial design. It is formed by Matt Muller (RISD Furniture 2014), August Lehrecke (RISD Furniture 2014) and myself (OSU Arch 2014). As a business we are about a year old, but as a studio I think we are just finding our flow. The past year has been mostly about forming a foundation. There's been steady commissions, and every project was a new construction technique and a new space. For us, challenging ourselves to design and make different things is a way to keep the practice interesting. Now that we have a comfortable footing, we are reassessing how we design and conceptualize. The next stage will be more varied design, architecture, and art.

J: A lot of your undergraduate colleagues from The Ohio State University decided to go to graduate school or work for a firm. What value do you see in taking an "alternative" path of practice?

L: I've always dreamed of starting a practice with friends. It seems like the most fun alternative: almost an extension of school, but in the real world. I also wasn't ready to commit myself to architecture. I feel like I need to play and make before I study again. Now running a business keeps me up at night, not to mention maintaining a studio, and building each project. Working at a world-class firm like BIG or OMA also teaches you countless things about architecture and design. I see what I'm doing as one chapter, eventually I'll work at a firm too.

Lots of credit goes to Matt and August for the idea of starting Pneuhaus. They went to school at Rhode Island School of Design, which stresses entrepreneurship a lot more than The Ohio State University. I didn't have any classes on business or lectures by successful alumni. OSU is an unaccredited undergraduate school so it's assumed that you will go to graduate school to become an architect. But OSU taught me about design and space; I felt totally ready to practice on my own.

J: Are you planning on going to graduate school at some point?

L: When I graduated from OSU the plan was to start a business for one or two years, then go back to school and start a career in architecture. But now I honestly don't know. I don't know how long Pneuhaus will go for, or what my mindset will be when I'm done. I feel like I need a good reason to go back to school, simply "to start a career" isn't enough, but I think it's in my future. For the time being, I'm concentrating on Pneuhaus, and when that's over I'll think about what's next.

J: Your project, Pneumatic Masonry, reminds me very much of a structure by Buckminster Fuller. Is there any correlation between Pneuhaus and the environmental movement of the 70's which focused on self-sufficiency through a DIY lens?

L: We are inspired by how inflatables impact people. People step into an inflated space and are awestruck. Inflatable are easy to make, but we have found that air is under-used as a medium in architecture, which is why we are excited to explore the possibilities of its use as a construction material. We relate ourselves more to Bauhaus because we work with people from different backgrounds and experiment with multiple mediums, bridging art and design.

SPACE WITH NO BRIEF

Andrew Dadds. Yale School of Architecture, M.Arch 2016

In the spirit of Le Corbusier's "Secret Laboratory," painting is used to explore the world around us through an idiosyncratic lens. Architecture, abiding by the laws of physics, and painting, with its freedom to manipulate objects and environments, are predomi-



nantly disparate. Le Corbusier embraced the dichotomy, allowing one to indirectly influence the other. Each day Le Corbusier would extend his morning exercises to each half of his brain, first the artist through non-functional painting, then the architect through professional practice. Many artist-architects have followed similar pursuits, from Piranesi to Massimo Scolari, free to construe architecture and its context in the plastic realm of painting. The space to be explored is within the canvas, and our eye the departure point. To project oneself in a painting is key to exploring it, leaving behind the physical constraints in which real buildings operate. Embracing paradox, mimesis, and contradiction in the canvas is an important exercise in our conception of space. The accompanying images exist free of any design brief or constraint. They are works of fiction, allowing for an exchange of properties both natural and artificial. A geography of the psyche, where one is free to explore. Abandoning the digital box in favor of representing the real as an open-ended question, painting can offer a pause to work intuitively and reflect upon a world all too often seen as literal.





The fern gardens in Golden Gate Park are extremely bizarre on their own, but we had a dance party and poetry reading outfitted with dramatic purple smoke on a nice summer day in the already awesome setting.



AGILE ARCHITECTURES

One issue I have always had with architecture is that it typically involves clients. Clients, when they invest in architecture, usually expect some kind of return on their investment, and in this sense, they almost always bring capitalist relations to bear on the design process. This is fine unless you happen, like I do, to wish for an architecture that moves beyond the determinism of prevailing power structures. Because of its immense cost, the production of buildings is a difficult thing to wiggle out of these determining forces. I have argued in a previous issue of *Paprika!* that perhaps subversive architects should be ready to let go of producing buildings altogether, favoring instead a radical *misuse* of the existing built environment, with the architect becoming more of a hacker of spatial softwares than a top-down manufacturer of spatial hardware. Here, I'd like to present a caveat to that repudiation of the production of actual built form.

In the weird world of business "theory", a new paradigm is taking over: agility. Companies, rather than investing tons of resources into a product in order to perfect it before its launch will release a "minimum viable product" (MVP), which they test in the actual marketplace and iterate upon in a series of releases. First introduced in the software world, agility has recently witnessed broad success in the world of hardware production as well. Can architecture learn something from this?

Upon returning to San Francisco (where agile jargon has annoyingly made its way into the everyday lexicon) as a YSOA graduate, I began two organizations in which I have been testing these and other questions hatched during my graduate studies: Nookzy, which is a peer-to-peer spatial amenity sharing platform that uses the market to encourage sharing behaviors that ideally will continue more effectively in a non-market context; and Spontaneum, which is a fast-growing group dedicated to throwing illegitimate events that misuse urban spaces, turning parking lots into movie screenings, underpasses into naked dance parties, and deploying select illumination of unrecognized features of the city as a means of elevating these to monument status, along with other seemingly nonsensical urban interventions. For Nookzy, the improvement of tiny spaces on a very low budget is made possible by the fact that the company benefits from altering the spaces of the hosts because they will then have a higher occupancy rate, yielding more income for all parties. Nookzy pays for the adjustments, and this is a new and interesting way to deliver design services in an "agile" kind of way. As a first "MVP", I fabricated a small, \$3,000 two-story building that hosts 8 hammocks, an upper deck with an enclosed, 18-foot canvas yurt structure, and a sharp, radial form, complemented by 18 sheer, bold red curtains, which we erected at Burning Man. It was a popular feature of Black Rock City, and so we are going to find it a permanent home in San Francisco, where it can be booked by Nookzy users on an hourly basis (hopefully we can stick a few \$300 inflatable hot tubs in there as well). This is low-budget design in which the designer has total control of the whole process because it is inexpensive.

In any case, Spontaneum is the more interesting example, in my opinion, because it uses minimal structures to alter the experience of existing spaces.

For our events, it often is the case that some small amount of infrastructure is needed. At the bare minimum, Spontaneum needed a generator for remote electricity, some speakers, and some bold lights—hard to come by for a decent price, but fortunately, the widespread practice of indoor marijuana cultivation has brought cost-effective, impractically bright lights that have no green spectrum, and whose output therefore appears pink into the marketplace. Super bright pink grow lights are therefore readily available to the urban hacker who wants to set out to contrarily illuminate corners of the city that nobody seems to appreciate. None of this gear can't be had by Friday with free two-day shipping, and so it is a replicable set of tools that we have used in our initial

hardware. A new strategy, which I have grown rather fond of recently, is the use of colored plastic cling wrap over existing lighting in indoor and outdoor spaces, such that the illumination is tinted with whatever hue the hacker desires. We do what we can to keep the costs down and the events free. We borrow stuff from friends; we use tools and toys in multiple ways; we try to achieve the maximum effect with the minimum material; we rarely get permission (permission is expensive!); we have eliminated the client completely. I believe we have accomplished a minor instance of architectural self-valorization.



We had our second movie night projected on the side of a defunct cluster of grain silos on San Francisco's Pier 92. Drawing around 50 people, it was our largest event yet, and involved a movie theater projector that a friend scored on Craigslist from a theater that was shutting down.

SUPER SHELTER MANIFESTO

0. Context:

Our work is not about amusement, neither is it about originality, «coolness» or some pretentious form of intelligence. Our manifesto is of course a constant work in progress, as long as there is other work progressing. It stems from working and thinking in a group, without ever abiding to any rules of strict alignment but always in consideration of a spirit of «togetherness».

Within the overabundant idealization of cooperation and sharing, the decision to come up with a manifesto might seem naïve in itself and to a certain extent it is. After all, we have been sharing thoughts and work for only five years and despite the intensity of it all, we are only starting to outline a functioning collective premise. A manifesto serves exactly this purpose, and nothing more.

However, the form of the old-fashioned manifesto, a poignant set of observations introducing a clear and specific call-to-arms, has been rendered useless and ridiculous by its repeated usurpation in the times of generalized intellectual carelessness leading up to now. A manifesto has come to mean a desperate attempt to market commercial apparatuses as groundbreaking and radical, when in truth there is absolutely nothing to see or discuss, other than the latest iteration of utter pointlessness. We tried not to be entirely

defeated by this hopeless scheme, carrying on with a manifesto that is a declaration of common course, a set of observations that we all cherish and guide us through our still precocious practice, although in the most loose of ways.

1. Observations on our mental condition:

1.1 PRINCIPLES

We are facing a total breakdown of our Ethics. Living can no longer be based upon inadequate and unsustainable principles; we need to head towards a much wider Ethical system, in which the planet would participate as a whole.

1.2 FACTS OF MATTER

Everything is connected to everything. Everything's got to go somewhere. There is no such thing as a free lunch. Abundance of energy, due to fossil fuels, has allowed us to live without slavery. Once there was the issue of food sufficiency, now there is the issue of obesity. All of this will soon be over, one way or another. Scaling everything down is the only pragmatic option going forward.

1.3 PAST

Human history is not the history of civilization. We are learning the latter, a fancy collection of founding myths, a heroic patchwork of agropastoral achievement. We study stories of growth and glory and then pretend to ignore to the inevitable collapse. You call 8000 years of this history? It is a mere joke in front of the million years of history; that of the species, its food and its resources.

1.4 FUTURE

No one can tell what the future holds, but "optimism" and "pessimism" are identically ridiculous. In a context such as this one,

one must carefully study present and past, both with the mind and with the hands. "Hope" is a construction that can only be based upon know-how and strategy, rather than the spontaneous expressions of human psyche.

2. Observations on our geographic condition:

2.1 TERRITORY

Modern territorial construction cannot be salvaged or repaired. Just like Roman territory it will collapse as long as the institutions that hold it together will themselves fail to survive. Our current pile of infrastructure will neither vanish nor survive; it will stand there waiting for alternative meanings.

2.2 PALIMPSEST

Authentic territorial reason will take over the current palimpsest. The man-made landscape was crafted by man's means to follow man's needs, which in the last centuries spun off any conceivable dimension into total abstraction and thorough absurdity. Happily, territory minus energy/slaves becomes once again the domain of reality.

2.3 INSIDE OUT

The endeavor to engulf the Earth as a whole within human codes and laws is vain. With the field now evenly covered, it emerges that an interior condition is neither possible nor desirable; the real territorial challenge will be about dealing with the outside.

3. Observations on architectural culture:

3.1 CONSTRUCTION

Architecture currently has a scope of action that is blatantly overstated. Good news, the conditions in which "everything is possible but nothing is decisive" will disappear, as they should. Construction shall be again the theme for architecture as instrument.

3.2 ADAPTATION

We are neither naïve nor craftsmen. Architecture as a discipline should redefine its boundaries, no longer dictated by technical ideals but rather based on a language of careful negotiation with the non-human.



3.3 INSTRUMENT

Construction is nothing but an instrument for adaptation. It is a means to an end as much as it is an end in itself. Consequently, construction as instrument should be a large-scale embodiment of the constant mediation between men and habitat, a powerful, ambiguous offspring of image and tool.

3.4 SUBJECT

Architecture is concerned with the individual as much as it is concerned with that



which is shared. The instrument that deals with the "outside" can be understood through the themes of individual survival; heating, moving and eating. However, the collective subject doesn't lose any of its interest. It is in fact more important than ever, when survival becomes ritual, and resources become the commons.



INTERVIEW W/ PEGGY DEAMER

Peggy Deamer, Assistant Dean, architect, writer, and founder of the Architecture Lobby, took some time to answer questions about independent studies, the Architecture Lobby, entrepreneurship

P: Peggy Deamer, R: Rob Yoos

R: What have you been working on this past summer?

P: Several things; continuing the research that I began this summer on the effects of the Sherman Antitrust Act on the profession of architecture. That was the Arnold W. Brunner Grant I used to produce what basically is a white paper. I have also largely been working on the Architecture Lobby. A lot of it is turning it into a non-profit organization. There are two levels of the non-profit; one is advocacy and one is education. We are planning two events; one is in relation to the upcoming Architecture Biennial in Chicago and I encourage students to participate. We're not one of the official invitees, but we are doing a kind of gorilla-renegade type installation at a gallery there. So there is a lot of work in preparation for that. One of the other things we are working on is making a proposal to be one of the participants in the 2016 Venice Biennale. The Architecture Lobby is growing, we're starting student chapters, and there is a leadership kit going out for chapters at different schools across the country. I'm also overseeing the construction of a small house in New Zealand. I can also say, that when I'm in New Zealand, I am going to be an advocate for a couple of things, one of which being for women in the profession. I organized a symposium with Brian McGrath at the New School last April titled "Feminism and Architecture Part 2: Women, Architecture and Academia." I will also be acting as an advocate for alternate forms of practice. Big firms do institutional buildings and small firms do houses, but you don't hear about anybody who is actually thinking about collaboration, new materials, and alternate modes of working, and there's not a real research culture there. So I'm planning on writing papers and giving talks to highlight these issues.

R: I'm curious if you're familiar with the Martell Symposium at the University at Buffalo. It was titled "Beyond Patronage" and it highlighted twelve female architects exploring alternate modes of practice outside the typical relationship of architect and client including Georgette Theodore, Lori Brown, Yolande Daniels, and Natalie Jerimijenko among others. Joyce Hwang and Martha Bohm organized this back in 2012 and they've been working on a book that is about to be published through Actar Publishers. However, the topic seems to have not gotten much

attention within the broader architecture community since. I think there is definitely more that needs to be done to advocate for that part of the profession. Could this sort of research start with students at the independent level at school? What do you think the role of independent research for students is at Yale right now and would you like to see more of it?

P: I'd love to see more of it. The option to do your own independent research for credit is less taken advantage of than it used to be. There used to be many

more students who would apply for that than do apply for it now. I think there is more complacency with the students around accepting the curriculum for what it is. I think it's healthy for students to individualize their education and take advantage of Yale. It's the perfect size and there is a sympathetic faculty. Students should take advantage of Yale to cater to their needs and desires a bit more. I think that's a positive thing. How can you make the practice that you want as opposed to waiting for the bathroom? Independent research goes hand in hand with preparing yourself for something different. I don't think our curriculum right now is set up to do that so well.

R: Independent research doesn't seem to be as encouraged as maybe it should be.

P: No one's there to encourage it. It's for students to take advantage of. I don't even know what encouragement would be. I'm not trying to blame the students, but just thinking about what the forum is for noting other courses that are in the book that you can take, including independent research.

R: Could you tell me a little bit more about the challenges working with the Architecture Lobby remotely from New Zealand? Is your goal more to set up a strong framework right now and then redistribute the power structure so that the organization can exist independently?

P: In some way there's not an automatic compatibility with growing the Lobby and being abroad; I can say optimistically, however, that having this time gives me an opportunity to concentrate on the Lobby. One goal is to really diversify leadership. I do think it is the case that others count on me to initiate things and follow through on things. A lot of people spend lots of time

and they're fabulous, but it's still the case where if I am not coordinating these interactions between people, they might not happen. I think everyone recognizes that and they don't want that to be the case as much as I don't want that to be the case. I can certainly monitor things like I do now, as long as I have internet. I think it will change things and I hope for the better. It could be that we could lose the momentum and I'm hoping that is certainly not the case.

R: Well, it seems that the Architecture Lobby already has a robust platform at Yale through the student body. There was definitely a ton of interest in it last year and I think that the momentum will carry on. I think it really is a responsibility of students to promote awareness among other architecture schools in our community to foster one big network of support. Hopefully we will see that happen over the next year. Are there other schools that have shown promise in developing their Architecture Lobbies?

P: The schools that have been the strongest so far are University of Michigan and IIT and I think they have (shown promise) because of particularly strong student leaders. Those two leaders have since graduated; the one at IIT is actually teaching there now so that can continue. I recently visited and there were a whole bunch of people there interested in participating so that group will definitely be intact. The person who is taking over at Michigan, we'll see how that works. Those are already intact and growing. The Lobby at U.C. Berkeley is seeing considerable growth and we've recently been contacted by Temple University in Philadelphia and University of Maryland. SAIC in Chicago has also recently joined which really is great because that makes Chicago a city with two schools now affiliated with the Architecture Lobby and allows for conversation to exist between the two schools as opposed to being isolated in their efforts. We have someone who is interested in the Lobby from the University of Pennsylvania who doesn't want to be a chapter head, but whose politics are in the right place and I suspect that other people in Philadelphia will express interest. And then there's Columbia, which has been consistently strong and has recently composed a symposium that seems fairly robust.

R: It's a matter of diversifying leadership among these separate schools. Is there potential for a unifying leadership among all

of them at some point? Or could there be an annual student symposium similar to the way the student chapter of the AIAS functions?

P: I think that's interesting. The answer to that is yes. I think we need to establish a balance between recognizing that schools all operate differently, the way students organize and how often or how much do they integrate with the student union etc., is very particular because at the same time there is a common structure so that everyone isn't making it up on their own as they go. We're planning a big town hall meeting in March that isn't particularly organized around student leaders, but is more to attach labor discourse in architecture to larger labor issues so that we don't see ourselves as part of a larger economic movement. The idea of having a student symposium is a fabulous idea and I think that would really be smart. Let me write that down! What has been so interesting for me has not just been the politics or whether the Lobby grows, but rather it's just having people meet like-minded people who want to make a difference in our profession and community, and to me, that's what this is really all about.



A CONVERSATION WITH KENT BLOOMER

Kent Bloomer, Professor Adjunct, sculptor, designer, writer, and founder of Kent Bloomer Studio, sat down to talk about Charles Moore, the 70's, and sailing.

J: Jessica Angel, D: Dorian Booth
K: Kent Bloomer

D: We are fascinated about the early building project, the band shell in Bridgeport or the pavilion at Light-house Point. What is, in your point of view, the difference between the pedagogical or ideological underpinnings of those compared to today's project.

J: And the idea of autonomy or self-sufficiency that was in the air back in the day. How Rudolph Hall was, you know, not that clean. I feel that it became a little bit corporate.

K: A little bit? You mean a lot! So did the profession, the whole thing did. I mean it's funny seeing Yale this corporate when in fact it is quite less corporate than most schools and compared to the profession. It's kind of a long story.

D: Let's start with Charles Moore and his perspective on all of this. His pedagogical views and how that contributed to the birth of the building project.

K: Charlie, Charles Moore, did not like the culture of the drafting room. He didn't think it was a constructive culture. I could tell you some extraordinary stories that evidence the truth of that. I think he saw the drafting room, what you now call the studio, as a site that took you away from experience and, in those days, put you at a drafting board. But now it's putting you on a computer which, in my perspective, takes you even further away from the drafting board. With the drafting board, which is a semi-manual device, you're still doing something physical. With the digital, with the fingertips

Instead of your whole arm, there's a second loss. The alternative to it is actually visiting buildings. Squatting on them. Eating in them.

J: Do you think the general atmosphere was more fun and more experimental?

K: Very much, very much. For example, if I were to critique the present scene, I would say that it's still the best school, and Yale still to me is a remarkable school, but in comparison to those earlier years in the 60's and 70's, if you went to a review of a first or second year, or even a third year work, you would see a much greater variety in what was being produced.

You also saw, in those days, radical stuff, like students designing stuff based on space ships. They would actually use the mechanics and robots and stuff like that to come up with an aesthetic or a style or a building that wasn't using technology or wasn't a technological model. It wasn't unusual for students to have old cars and bring parts of the engine and build parts of an MG right in the studio.

It seems to me that architecture itself has become much more of a profession than it was then. It was somewhat of a loosey-goosey profession then. So Frank Lloyd Wright could take his students to Taliesin West and they would make pots and ceramics. Or Paolo Soleri, the Italian architect, would take them out into the desert and they would make bells. He would get them to make mounds of sand, and then they would make a concrete shell structure out of the sand, and then they would make bells.

D: How much of that culture do you think was responsible for what was happening with those kinds of experiments or this

general tendency to be more physically connected to whatever you're building or producing?

K: As architecture became more professional, the kind of buildings that were being designed got bigger and bigger. I mean, there's a lot of house design, or small building design. In large buildings, everybody knows you can't go out and build it yourself. What I did was turn to ornament because I thought that ornament was the last

J: In the back of my mind I'm thinking a lot about the environmentalists of the 70s, the Whole Earth Catalog, and the idea of making was all linked to the fact that NASA had released pictures of the planet. People started realizing the impact of what humans were doing on Earth. And the situation is not better nowadays.

K: It's not, it's worse.

J: And so I'm wondering why we left that. It's nice to talk about the 70s but I'm also trying to understand the fall. Why did we suddenly say "Oh, this is

K: That's actually a good question. I'm a sailor, I'm a boat person. People on the water who have boats are extremely environmentally conscious. If you have a boat, and you're sailing on the long island Sound, you're going to be the person that prevents pollution on the Long Island Sound. If you have motor boat, a speed boat, you're less likely to care because the sound of the engine, the thrill of speed makes you insensitive to the surface of the water. And you don't see the filth that's beginning to accumulate. So it is the sailors that protect the Long Island Sound.

D: I think that how we, as architects, accrue knowledge, and whether it is entirely theoretical versus something that is physically learned, is important. How does that affect us? I don't know if it is because people are terrified of making a mistake, but why don't people take a chance and let something evolve organically, as a process of discovery? How did that come about?

K: I think the schools are at fault, not the students. Yale, under Charles Moore, was a pioneer in getting the students to build things. Prior to that, Spain was quite interesting. Spain used to require that students build stone arches. You understand that if your arch is too shallow, and the force goes out of the line of the axis, it will explode.

I think we theorize too much. And why do we theorize

too much? Because that's how universities work. They've become more German, they love the PhD system. The theory of architecture is taught by PhDs, not by builders.

The tyranny of the modernist paradigm has led to an increasing propensity towards abstraction. You're looking at a domain of thinking that is very purified, that is very sanitized. It looks good because it is clean and it fits the historic model of modernism. But I personally think that that lead us away. It leads to abstraction, and the more abstraction the less hands on work.

D: And also an attitude that craft and handwork, or manual work, is somehow lesser. So I wonder, how did those early building projects differ from the ones done today?

K: It was more visceral. I remember the first building we did I dug the septic field, along with Turner Brooks, he was a student. The projects were definitely smaller, and it was not unusual that this was criticized. People like Turner Brooks, or the Prickly Mountain crowd, all Yalies, never built large buildings. As the school became more under the watched eye of the New York crowd, then obviously big buildings had to come into play. When big buildings came into play, that plus urban design, tended to increase the size of the scale of the buildings and the projects. And that led towards a kind of abstraction. Whereas the students, in the summer, would build a house for their mother. Everybody had somebody that gave them a porch to build, and they'd do it.

During your student years, when you're developing your own creativity, you shouldn't be doing big projects. I never remember this being said out loud, but I think the sense was let's not try to get them to design things that are beyond what they can experience. The experience could be either building the building itself, or a piece of it, or the experience would include visiting the building and eating and sleeping in it. That was the experience that was dominant in those years. And the students were very excited by building. They built and built.

The great thing about Yale is that you can just do it. No one can stop you. If you want to do more stuff in 3D and build it just go ahead and do it. I think that the students have become too concerned about job getting. Do that in the last term, but don't do it the rest of the time. You'll figure out how to build the large stuff, you don't have to do it now.

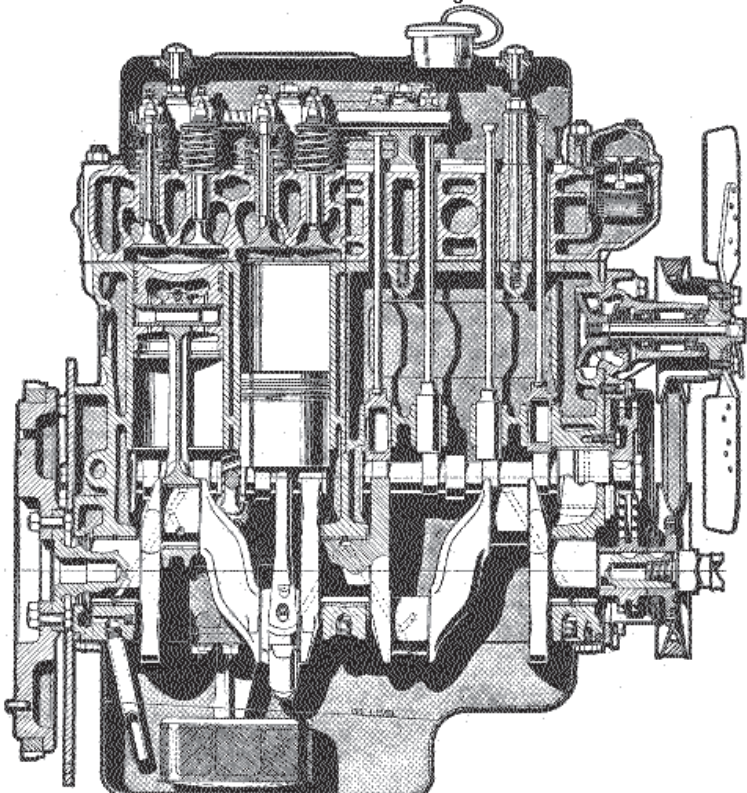

The M.G. (Series MGA) Engine Based on the B-Series Engine Block